



Touch screen weight indicator perfect for any type of weighing

Practical, easy to install and use

Perfect for static weighing and loading-unloading and multicomponent dosage

Customizable according to necessity

Multilingual menu

6 inputs and 6 outputs (optoisolated 24 Vdc)

Internal data memory 64 Kbytes expandable up to 1024 Kbytes

Fieldbus + analog output on board at the same time

**TECHNICAL CHARACTERISTICS MCT 1302 ETHERNET IP**

Power supply:	5 Vdc (max 8 -350 Ohm- load cells)
Measuring range:	-3.9 ÷ +3.9 mV/V
Input sensitivity:	0.02 microV min
Linearity:	< 0.01% FS
Temperature drift:	< 0.001% FS/ °C
Display:	graphic LCD (240x128 pixel)
A/D converter:	24 bit; internal resolution up to 16.000.000
Frequency signal acquisition:	12 ÷ 1000 Hz
Displayable resolution:	999.999 displayable divisions on net weight
Value divisions (selectable):	x1, x2, x5, x10, x20, x50; 4 decimal point
Filter:	selectable 0.1÷250 Hz
Keyboard:	4 wires resistive touch screen
Power supply:	10-30 Vdc - Power consumption 5 W
Operating temperature:	-10/+ 50°C (humidity max 85% no condensation)
Storage temperature:	-20 ±+70°C
Logic outputs:	6 opto-isolated; max 24 Vdc/100mA each
Logic inputs:	6 optically isolated 24 Vdc PNP (external power supply)
Additional I/O:	up to 4 external modules with 4 in/8-out each (16 in/32 out, total) by independent RS485
Serial ports:	1 USB device + 1 RS232C + 1 RS485/Fieldbus
Optional analogue output:	optoisolated 16-Bit Voltage: 0 to 5/10 V (R min10 K Ohm), Current: 0/4 to 20 mA (R max 300 Ohm)
Analog output calibration:	keyboard (touch screen)
Analog output linearity:	< 0,02% FS
Temperature drift analog output:	0,001% FS/°C
Microcontroller:	ARM Cortex M0 + 32 bit 256KB Flash reprogrammable onboard from USB
Data storage:	64 Kbytes expandable up to 1024 Kbytes
Regulatory Compliance:	EN61000-6-2, EN61000-6-3 for EMC; EN61010-1 for Electrical Safety, EN45501 for metrology
Electrical connections:	removable screw terminal blocks (3.81mm pitch) 150x95x26mm (LxWxH) including terminal blocks;



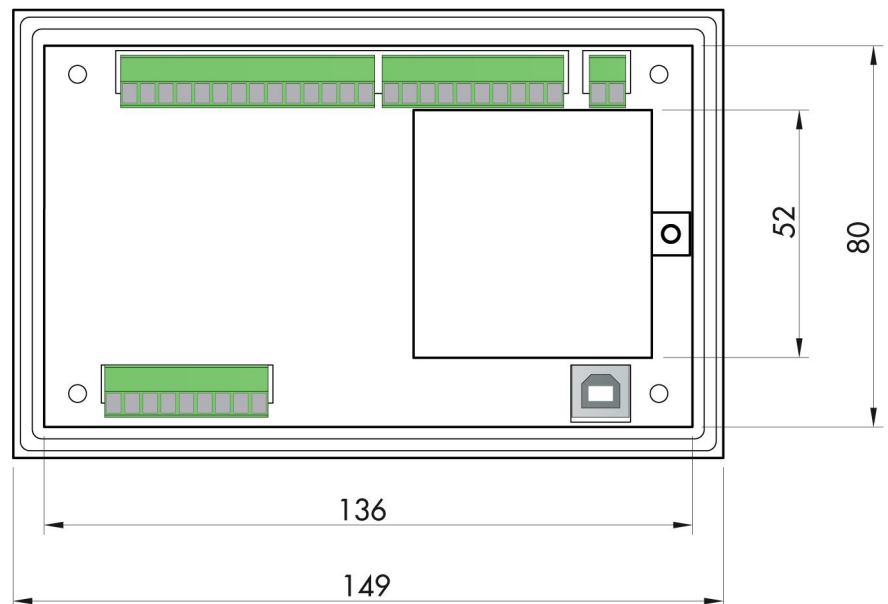
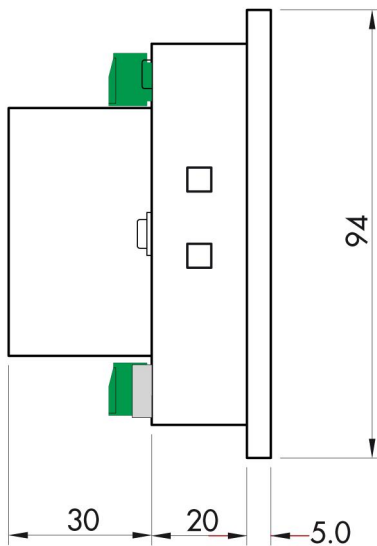

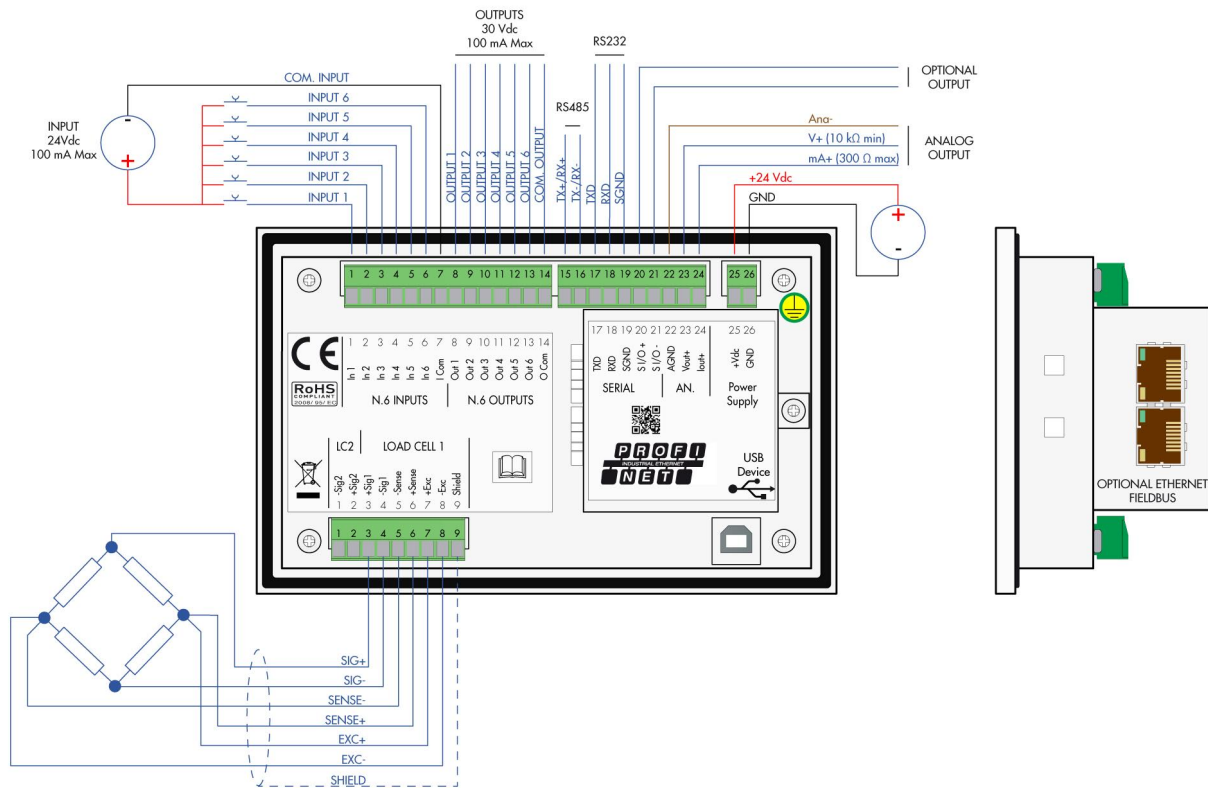

**SCIGATE AUTOMATION (S) PTE LTD**

No.1 Bukit Batok Street 22 #01-01 Singapore 659592

Tel: (65) 6561 0488

Fax: (65) 6562 0588

Email: sales@scigate.com.sg

Web: www.scigate.com.sg

Business Hours: Monday - Friday 8.30am - 6.15pm

